

TmaxTM

Extreme Transaction
Processing

TmaxSoft





Tmax Extreme Transaction Processing

Tmax Overview

Mission Critical Legacy Application Supporting TP-Monitor, Tmax. Dramatically improves system performance, stability, and reliability.

Tmax (Transaction MAXimization) is a transaction process monitoring solution (TPM) that optimizes transaction processing within distributed systems that are composed of multiple heterogeneous server. Tmax facilitates the processing of mission-critical legacy applications and provides an optimized computing environment for developers and system administrators.

Tmax ensures system reliability through load balancing and fault tolerance in important systems in which tens of millions of transactions occur in a day, in a variety of industries such as financial, manufacturing, public, communication, and distribution.

- Complies with X/OPEN DTP DTP (Distributed Transaction Processing) standards, the international standards for distributed transaction processing.
- Defines APIs and system interfaces between functional components for distributed transaction processing (DTP) services of international standard OSI (Open System Interconnection Group).
- Transparent application processing and OLTP (On-Line Transaction Processing) supporting within distributed systems
- Satisfies ACID (Atomic, Consistent, Isolated, Durable: transaction properties) of transaction processing TP-monitor (Transaction Processing Monitor) is a transaction management middleware which monitors transaction, the minimum processing unit operating in a variety of protocols in session, system and database.

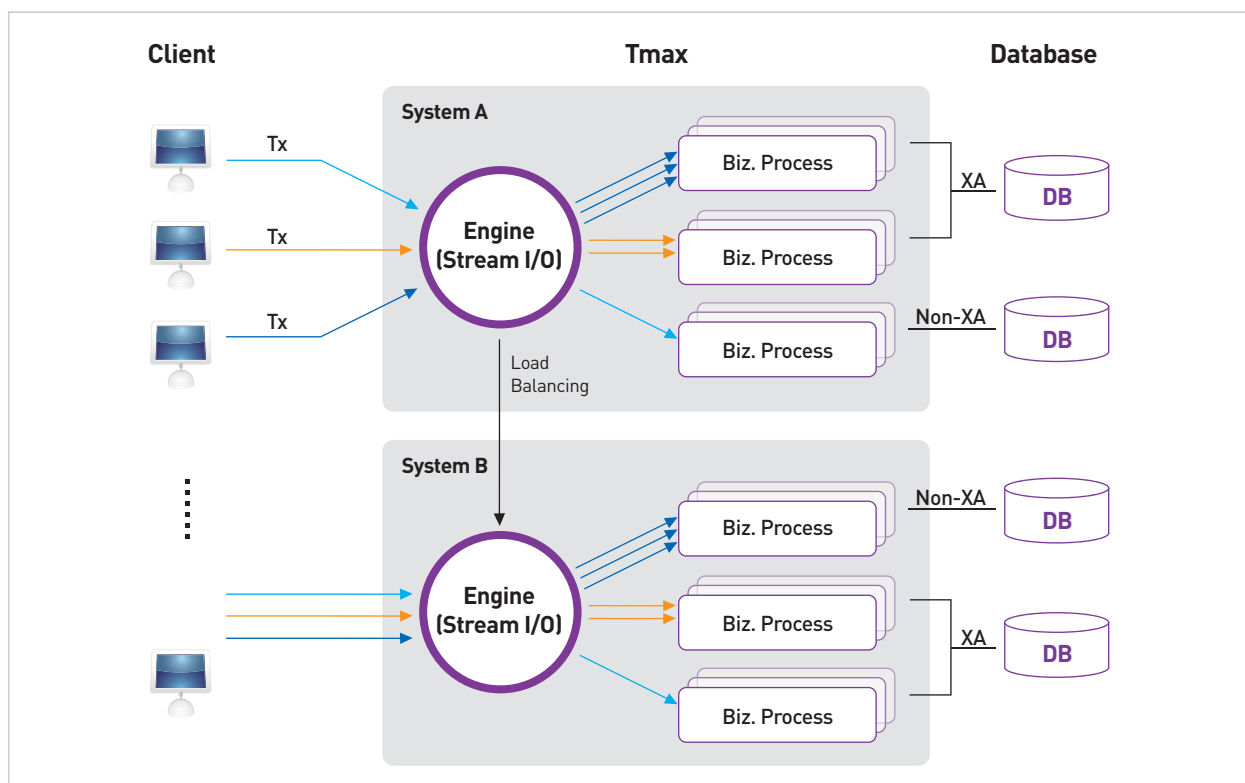



Tmax Extreme Transaction Processing

Tmax Features

Tmax-based systems are composed of multiple nodes (real or virtual machines) linked together in a peer-to-peer relationship instead of the traditional master/slave model. Tmax manages a Remote Access Control Daemon (RACD) within each node, each of which maintains communication with the RACDs of other nodes. Tmax uses a superior stream pipe communication method for inter-process communication instead of the traditional message queue method. This ensures that inter-process communication remains stable, prevents memory resource wastage, reduces the occurrence of 'Queue Full' errors and avoids situations where excessive transaction volumes slow down the network.

Complete compliance with international distributed transaction standards

- 100% complies with X/OPEN DTP international standards
- Defines APIs and interfaces between functional components for OSI (Open Systems Interconnection group) DTP services

Competitive architecture

- Stream I/O (Pipe) type IPC (Inter Process Communication) implementation to improve protection, and multiplexing efficiency
- Improves performance and stability by adopting peer-to-peer relationship instead of the master/slave model and enhances convenience by supporting centralized management over each node

Fault Tolerance, Fail-Over

- H/W and S/W fail-over
- Various fault tolerance (Queue Full prevention, priority configuration)
- Fast recovery of engine failure

Scalability, Flexibility

- Provides system flexibility in the event of client increase
- Ensures performance in the event of vertical or horizontal expansion
- Efficient conversion from 2-Tier model to 3-Tier model by using CA (Client Agent)
- Provides various protocols such as TCP/IP, SNA, X.25, and Web Services for legacy systems
- Service expansion to Web environment by using WebT
- Supports various process controls
- Supports Hybrid Messaging System

Supports 24*7 continuous environment

- Supports dynamic application module and application update function (Tmax Dynamic Library) while the system is running
- Supports dynamic system control functions such as service and server addition and environment configuration change
- Provides convenient management environment based on both of Web and command-line console.

Supports the use of diverse message types, communication modes

- Supports the use of variety of message types: Integer, Long, Character
- Supports the use of synchronous, asynchronous, conversational, and forwarding modes.
- Supports the use of FDL(Field Definition Language) and Structure Array



Tmax Extreme Transaction Processing

Tmax Key features

Process management

The number of active server processes can be automatically monitored and controlled in order to optimize system performance.

Transaction management

By supporting 2 Phase Commit, Tmax secures transaction integrity in case of system service failure. Simple functions like tx_begin, tx_commit and tx_rollback facilitate reliable global transaction processing. Multi-thread type transaction manager enables efficient resource use and dynamic logging enables quick error handling.

Load balancing

Tmax transaction process monitoring can monitor transaction requests and route them to specific nodes to make sure that no section of the system becomes overloaded and optimize overall system performance.

Fault Tolerance

With service backup, server process automatically restarts, ensuring seamless service providing.

Support of user control server process

Tmax supports the use of three different types of server processes: TCS (Tmax Control Server), UCS (User Control Server), POD (Process On Demand)

RQ (Reliable Queue)

Tmax stores critical data on the disk in order to prevent data from being lost in the event of system failure or server processes being restarted.

System management

Provides administrators with a comprehensive, real-time view of the entire system, including the status of server processes, queuing

status, the number of transactions processed, and average processing times. Additionally, TmaxSoft's APM solution, SysMaster, can be integrated into a Tmax system to provide service flow tracking and event handler allocation functions, enabling administrators to perform system analysis.

Multi-domains and various gateway modules

Supports interfaces for mutual data change in long-distance distributed system and for different platform-based systems. Provides a variety of gateway modules such as SNA, CICS, SNA IMS, TCP CICS, TCP IMS, and OSI TP.

Scalability

Web interface: WebT is TmaxSoft's web gateway solution that integrates directly with Tmax. This enables end users to access the Tmax system functions via the web using Java applets, Servlets or PHP.

Mainframe-system interface: Tmax-based systems can incorporate legacy applications residing within mainframe platforms through a simple client/server interface. This is accomplished by connecting the legacy system to Tmax through the Tmax Mainframe Gateway, Host-Link.

Seamlessly migrates applications from other middleware : Business applications from systems that use other middleware products (Tuxedo, TopEnd, and Entera) can be shifted to a Tmax environment without modification of the original business logic.

Dynamic application module update

Provides seamless distribution function and version management function for user applications which are developed as shared library format by using the dynamic library link technique provided from OS.

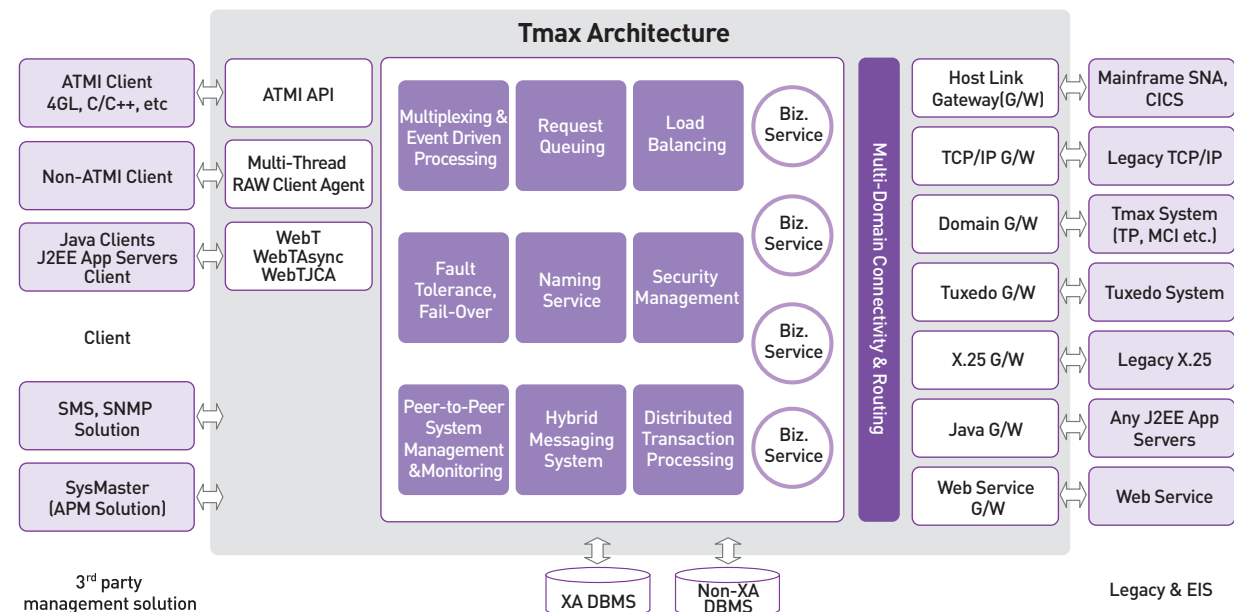



Tmax Extreme Transaction Processing

Benefits

Performance

Tmax-based 3-tier systems (systems that include a middleware layer) are significantly higher performance than 2-tier systems. Additionally Tmax's system management, load balancing, fault tolerance, security functions ensure the reliable system.

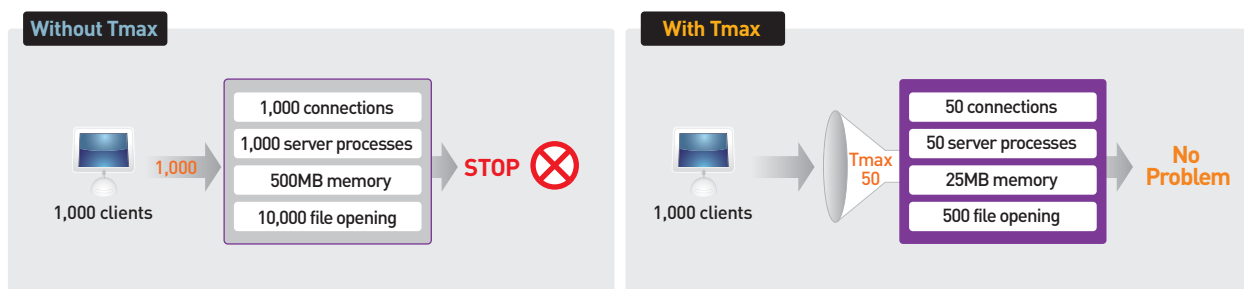

Costs

Tmax has low implementation costs and reduces the overall operating and expansion costs of any system. Because Tmax optimizes system capacity, hardware requirement and expansion needs are reduced. Furthermore, because Tmax implements a transparent system architecture, development productivity is improved and maintenance costs are reduced.

Tmax Implementation Environment

Operating system and platform

- Sun Solaris 7, 8, 9, 10(SPARC) 64-bit
- HP-UX 11(PA-RISC) 64-bit, HP-UX 11(Itanium) 64-bit
- IBM AIX 5.1~5.3, 6.1 (PowerPC) 64-bit
- Supports Linux, Windows, etc.

Protocol

- Application API: XATMI, TX TXRPC
- Integration API: XA, OSI_TP
- Network: TCP/IP, X.25, SNA development language

Fundamental environment

- Development language
 - Server: C, C++, COBOL
 - Client: C, C++, 4GL(Power Builder, Delphi, Visual C, Visual Basic, etc)
- DBMS: Oracle, DB2, Informix, Sybase, Tibero, etc.
- Memory: 128 MB or more (256MB or more is recommended)
- Disk: 30MB or more (100MB or more is recommended)

Tmax™

Korea Headquarters

272-6 Seohyeon-Dong, Bundang-Gu, Seongnam-Si,
Gyeonggi-Do, Korea, 463-824
Tel : (+82) 31-8018-1000
Fax : (+82) 31-8018-1115

R&D Center

272-4 Seohyeon-Dong, Bundang-Gu, Seongnam-Si,
Gyeonggi-Do, Korea, 463-824
Tel : (+82) 31-779-7114
Fax : (+82) 31-779-7115

TmaxSoft USA

560 Sylvan Avenue, Englewood Cliffs, NJ 07632, USA
Tel : (+1) 201-567-8266
Fax : (+1) 201-567-7339

TmaxSoft Japan

5F Sanko Bldg, 3-12-16 Mita, Minato-Ku, Tokyo,
108-0073 Japan
Tel : (+81) 3-5765-2550
Fax : (+81) 3-5765-2567

TmaxSoft China

Room 1101, Building B, RecReo International Centre, East
Road Wang Jing , Chaoyang District, Beijing, China
Tel : (+86) 10-5783 9188/89
Fax : (+86) 10-5783 9188/89-800

TmaxSoft